

LX 16

Audio -Variometer system
Pilots` Manual



1 Introduction

The LX 16 sensors are high quality pressure transducer, to guaranty high accuracy of vario signal and its zero point. A modern low-power microcontroller drives the LCD vario indicator and supports input controls. All necessary inputs are made using two push buttons on the bottom of the unit.

The vario has no on/off switch, we recommend that you install an external switch, or just use an avionic master switch. A 1 amp fuse must be installed.

2 Technical data

- 57 mm standard cut out
- 65 x 65 x 110 mm without connector and pressure inlet
- 3 ranges 5m/s, 10 m/s, 2.5 m/s (10kts, 20kts, 5 kts)
- Averager (20s)
- Flight time indicator
- Power consumption typically 50 mA/12V, (depends on audio volume)
- TE compensation: TE tube
- Weight: appr. 260 gr.
- Power supply: 8-16 V DC

3 How to use the unit

3.1 Setup

The unit is ready for operation immediately after power on and vario needle is back to zero. The following settings can be set up on the ground, and also during flight.

- UNITS (selection of m/s kts)
- RNG for selection of vario needle range
- FIL for selection of vario signal filter in steps from 1 to 4 (damping of response time)

To enter into Setup menu press **both push buttons** for approximately one second and UNIT item will appear. Press right button to select further menus (RNG, FIL). To change settings use left key. All settings will remain after power off.

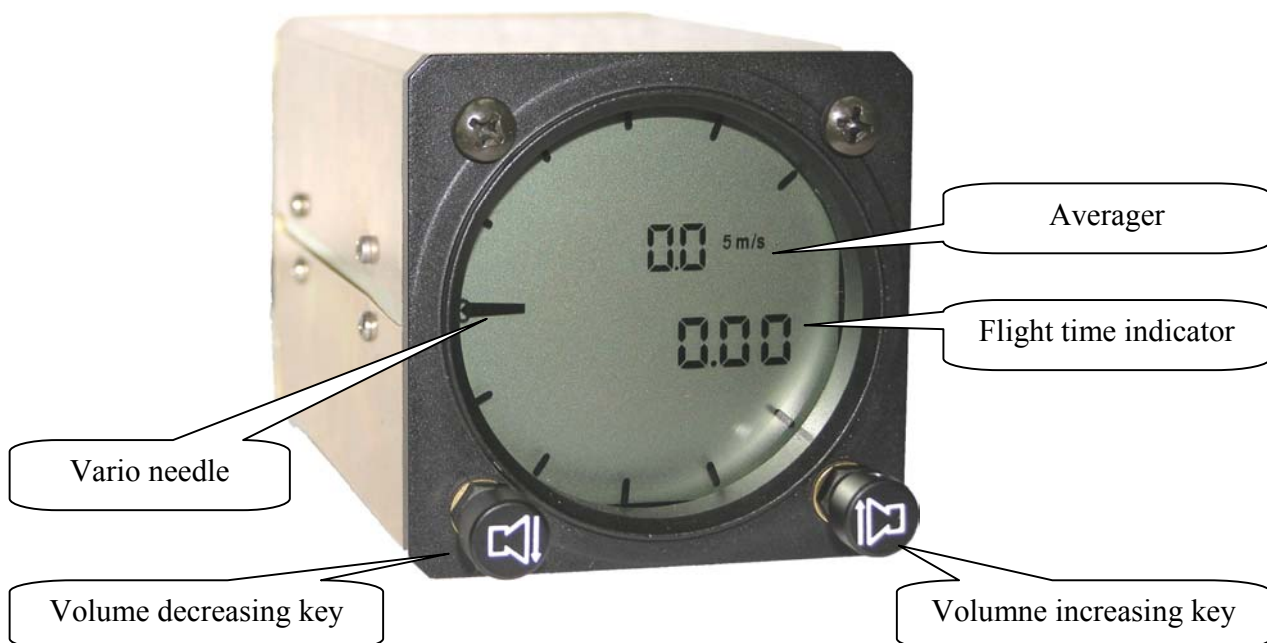

3.2 Changing of audio volume

- Press left button to decrease audio volume and vice versa. A longer press will change the settings more quickly.

3.3 Flight time indicator

The flight time indicator will show flight hours and minutes of the actual flight. The counter will be activated automatically after climbing will be detected. After landing the flight time indicator will stop automatically. A blinking decimal dot will indicate that the flight time indicator is active.

4 Installation

4.1 Mechanical installation

One 57 mm diameter circular cut out is required but you need to allow for the overall dimensions of the unit which are as follows:

65mm width
65mm height
140 mm length with connectors

The unit is attached by 2 hollow bolts at its lower corners and two M4 screws; the positioning of these holes is the same as any other instrument of this size.

Installation procedure

- Extend lower 2 instrument fixing holes to 6.5 mm
- Remove two buttons from axis, use special tool delivered with the unit
- Remove two bolts, use 8mm tool
- Insert LX 16 into the cut out and fix it using two bolts and two screws. Check functioning of push buttons, if they are blocked, place a ring (included) between the instrument and the panel to achieve the correct functioning.
- Fix both push buttons

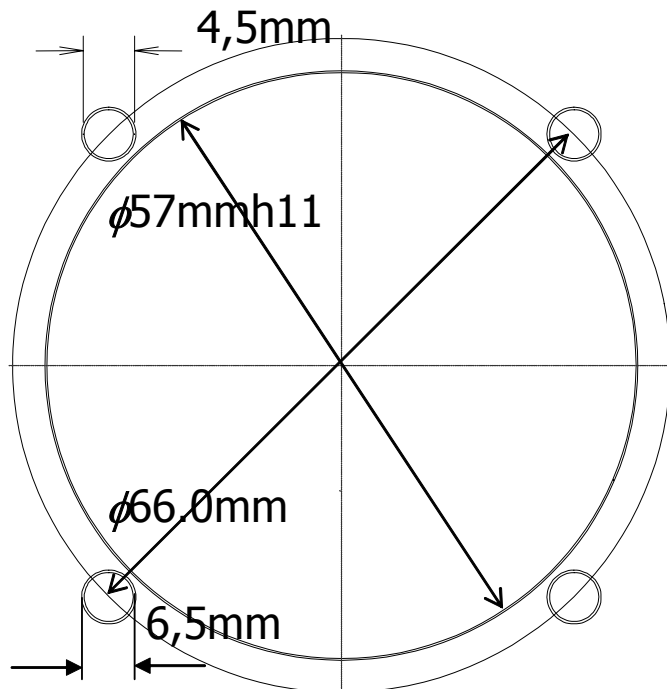

4.2 Pneumatic connections

There is only one pressure inlet on the rear side of the unit. It should be normally connected to the TE probe to ensure total energy compensation.

4.3 Electrical connections

The electrical connections are clearly marked (red + 12V, blue GND) and the pre-assembled cables make it very easy to connect all the components. The unit has no **ON/OFF** switch, use avionic master switch or install a separate switch.



Note!

There is no internal fuse in the LX 16 and you must install an external fuse with a rating of 1 amp (quick blow).

In the LX 16 delivery box you will find the following cables and accessories:

- Main power supply cable,
- LX 16
- Tool for knob installation
- manual.

LX navigation

 + 386 3 490 4670
 support@lxnavigation.si

 + 386 3 490 46 71
 <http://www.lxnavigation.si>

